



# Russell Hobbs



19772

 [www.russellhobbs.com](http://www.russellhobbs.com)

**Register online for an EXTRA year guarantee**

Visit [www.russellhobbs.co.uk/productregister/](http://www.russellhobbs.co.uk/productregister/) You must register within 28 days of purchase

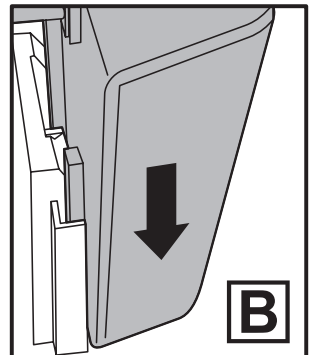
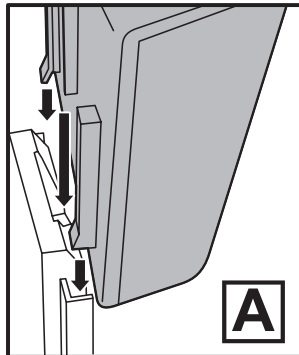
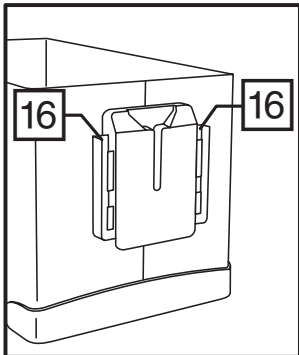
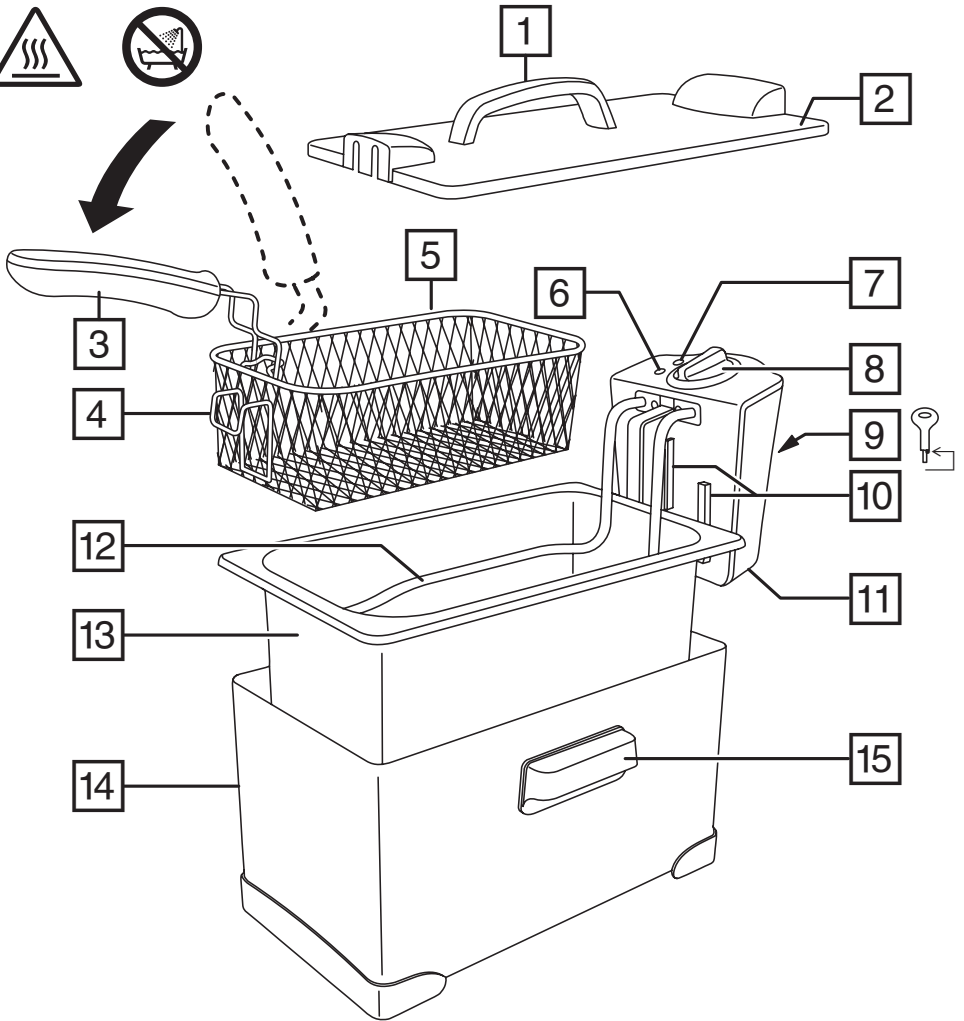

Read the instructions, keep them safe, pass them on if you pass the appliance on. Remove all packaging before use.

---

## IMPORTANT SAFEGUARDS

Follow basic safety precautions, including:

This appliance shall not be used by children from 0 year to 8 years. This appliance can be used by children aged from 8 years and above if they are continuously supervised. This appliance can be used by people with reduced physical, sensory or mental capabilities or lack of experience and knowledge if they have been given supervision or instruction concerning use of the appliance in a safe way and understand the hazards involved.

Keep the product and its cord out of reach of children aged less than 8 years. Cleaning and user maintenance must not be done by children.

This product must be positioned on a stable surface with the handles positioned to avoid the spillage of hot liquids.

 Surfaces of the product are liable to get hot during use.

Never operate the product by means of an external timer or separate remote-control system.

If the supply cord is damaged, it must be replaced by the manufacturer, its service agent or similarly qualified persons in order to avoid a hazard.

-  Do not use this appliance near bathtubs, showers, basins or other vessels containing water.
- Don't lean or reach over the fryer while the oil is hot.
- Don't carry or pass anything through the space over or near the fryer – if anything drops into the fryer, hot oil will splash out.
- Don't try to move or carry the fryer if it contains hot oil. Let it cool down fully first.
- Don't leave the fryer unattended while plugged in.
- Don't use the fryer without first filling, with good quality cooking oil between the MIN (2.8 litres) and MAX (3.3 litres) marks inside the bowl. If the oil level is below the MIN mark, you may damage the fryer. If above the MAX mark, hot oil may escape, causing damage and injury.
- Don't put the fryer under cupboards, shelves, or anything that might be damaged by heat or steam. Keep it clear of combustible materials like curtains, or drapes.
- Never let the power cord hang over the edge of a work top, touch hot surfaces or become knotted, trapped or pinched.
- Remove the lid from the fryer before use, keep it off while in use, and replace it only after the oil has cooled down fully.
- Unwind the cable fully from the storage area before use.
- Don't put anything on top of the fryer while it's in use.
- Unplug the fryer when not in use, before moving and before cleaning, let it cool down fully before cleaning or storing away.

- Don't use accessories or attachments unless we supply them.
- Don't use the fryer for anything other than heating cooking oil for deep frying.
- Don't use the fryer if it's damaged or malfunctions.

## HOUSEHOLD USE ONLY

---

### PARTS

- |                        |   |
|------------------------|---|
| 1. Lid handle          | 9. Reset button  |
| 2. Lid                 | 10. Guides  |
| 3. Handle              | 11. Heating/control unit  |
| 4. Basket              | 12. Element   |
| 5. Basket rest         | 13. Bowl  |
| 6. Power light         | 14. Body  |
| 7. Thermostat light    | 15. Carrying handle   |
| 8. Temperature control | 16. Grooves   |

### BEFORE USING FOR THE FIRST TIME

---

Clean the fryer, to remove manufacturing dust, etc. see 'care and maintenance'.

### PREPARATION

---

1. Sit the fryer on a stable, level, heat-resistant surface, at least 75cm above the floor, with at least 5cm space all round it.
2. Keep it away from cupboards, curtains, anything combustible, and anything that might be damaged by heat or steam.
3. With the basket in the fryer, and the basket handle unfolded, position the fryer so the basket handle doesn't extend beyond the edge of the work surface where it might be caught or knocked accidentally.
4. Line a colander with paper towel, to drain the food after frying.
5. When using your fryer, always use oven gloves. They don't just protect your hands from heat, they protect them from drips and splashes too.

### ASSEMBLY

---

1. Lower the bowl into the body of the fryer.
2. Engage the grooves on the control unit with the guides on the rear of the body (FIG. A), and slide the control unit into place (FIG. B). **If the control unit isn't fitted correctly, a safety switch on the unit will prevent the fryer from working.**
3. Put the basket inside the bowl.
4. Push the basket handle forward, and swing the handle down into the basket.
5. Replace the lid.

### FILLING

---

1. Remove the lid from the fryer and put it aside till you've finished frying and the oil has cooled. Don't use the lid during cooking.
2. If the bowl is empty, fill with good quality liquid cooking oil, to between the MIN (2.7 litres) and MAX (3.2 litres) marks. If it already contains oil, check the level, and top up as necessary.

- Don't use solid cooking oil, fat, butter, margarine, or olive oil. Olive oil generally contains too much water, and can be too smoky. Buy a good quality liquid cooking oil suitable for deep frying, like sunflower or corn oil.
- Don't mix oils of different types, as they'll have different temperature characteristics.

---

## USING YOUR FRYER

1. Turn the temperature control to the temperature you need. The range is 130°C, 150°C, 170°C, and 190°C.
2. Put the plug into a wall socket (switch the socket on, if it's switchable).
3. The power-on light will come on as long as the fryer is connected to the power supply.
4. The thermostat light will come on, then cycle on and off as the thermostat maintains the temperature.
5. When the thermostat light goes out, you can start frying.

### Prepare the food

- Cut food into uniformly sized pieces.
  - Coat wet food (e.g. fish, fruit) with flour, crumbs, batter, etc.
  - Don't try to defrost food in the fryer. Any food other than pre-cooked, quick-frozen foods (e.g. frozen chips, scampi in breadcrumbs, chicken pieces in batter) must be fully defrosted before putting into the fryer.
  - When frying pre-packed or pre-cooked frozen foods, follow the instructions on the packet.
  - When frying raw vegetables (e.g. chips), dry them with paper towel or a tea towel.
1. Put the prepared food pieces in the basket. Try not to put more than two layers of food in the basket. If you need to fry more, do it in batches.
  2. Using oven gloves, hold the basket by the handle and lower it gently into the oil.
  3. The oil will foam as it comes into contact with water from the food. As long as the foam doesn't threaten to overflow the bowl, this shouldn't be a cause for alarm.
  4. If the foam threatens to overflow the bowl, use the handle to lift the basket out of the oil, set it down on a paper towel. See HINTS AND TIPS for possible solutions.

### Frying the food

1. Stay in the kitchen, and keep an eye on the frying process.
  2. Don't lean or reach over the fryer while the oil is hot.
  3. Wait till the food has cooked then unplug the fryer from the wall socket (switch the socket off first, if it's switchable)
  4. Using oven gloves, lift the basket from the oil by the handle and hook the basket rest on the edge of the bowl to drain
  5. Empty the food into the lined colander to drain before serving
- Don't return the empty basket to the fryer, set it down on the paper towel.
  - If you've finished, leave the dryer to cool down before cleaning.
  - If you want to fry another batch of food, check the oil level and top up as necessary.

---

## COATINGS AND BATTERS

Coat all foods, except those high in starch, like potatoes and doughnuts. The coating protects the food, helps prevent juices leaking into the oil and gives a crisp tasty result. Generally, coatings won't stick to frozen foods.

### Seasoned flour

Thicker coatings don't stick well to wet/damp foods, so coat them first in seasoned flour. Use on its own to coat small whole oily fish like whitebait.

## **Egg and breadcrumbs**

Popular on fish, chicken, and scotch eggs, it gives an attractive, crisp, crunchy exterior. Ideal for foods that are to be served cold, as it stays crisp for hours.

1. Coat in seasoned flour, to dry the food. Dip in beaten egg, then breadcrumbs, repeat till fully coated. Press well, then shake off any excess.
2. Fresh breadcrumbs give a rough appearance. Make dry breadcrumbs or raspings by baking scraps of bread till golden, then crush or process to a fine crumb.

## **Basic batter**

- 100g self raising flour
- pinch of salt
- cold water

Just before it's needed, mix the salt and flour with enough water to form a smooth cream that will coat the back of a spoon.

## **Basic fritter batter**

- 100g self-raising flour
- 5ml (1tsp) cooking oil
- pinch of salt
- cold water

Sift the flour and salt into a bowl. Stir in the oil. Just before it's needed, stir in enough water to form a smooth batter.

## **Fritter batter with egg white**

- 100g plain flour
- 1 egg, separated
- 150ml liquid (cold water, milk, beer)
- 15ml (1tbsp) cooking oil
- pinch of salt

Sift the flour and salt into a bowl. Stir in the egg yolk, then the liquid. Beat in the oil. Just before it's needed, whisk the egg white and fold into the batter.

## **Crispy Chinese batter**

- 75g cornflour
- 1 large egg
- 10ml (2tsp) baking powder
- 5ml (1tsp) cooking oil
- good pinch of salt
- cold water

Mix the egg, cornflour, salt, oil, and enough cold water to form a creamy base on which to add either egg and breadcrumbs or batter. It holds the other coatings on the food.

---

## **FRYING TIMES**

Use these times purely as a guide. Check that food is cooked through before serving. If in doubt, cook it a bit more. Chips and other vegetables should be crisp. Cook meat, poultry, and any derivatives (mince, burgers, etc.) till the juices run clear. Cook fish till the flesh is opaque throughout.

### **Chips (french fries)**

- Use a chipping potato, like King Edward, Cara, Maris Piper, Romano or Desirée.
- Peel, cut, rinse, drain, and dry thoroughly. Don't put more than two layers of chips in the basket at a time. For best results, fry in two stages:

Stage 1: Fry for 5-10 minutes (depending on quantity) at 170°C. When the chips reach pale gold, and the outside is firm, lift the basket out of the oil, and let the chips drain and cool.

Stage 2: Fry for 2-4 minutes at 190°C. When golden brown and crisp, remove from the oil, and drain in a colander lined with paper towel.

### **Frozen chips (french fries)**

Follow the directions on the package.

### **Other vegetables**

Many vegetables may be deep fried – onion rings, mushrooms, cauliflower florets. They can be fried from fresh or frozen, and should be coated.

### **frozen food (small pieces in batter, breadcrumbs, etc.)**

- Frozen food cools oil quickly, so fry a single layer at a time.
- Keep the pieces apart, or they'll stick together.
- Shake off excess ice or water before adding the food to the oil.
- Use the highest temperature setting, and lower the basket slowly into the oil, to reduce foaming.
- For pre-packed food, follow the instructions on the package.

### **Fish – frozen**

You may fry pre-coated fish – follow the directions on the package.

<b>Type</b>	<b>Temperature (°C)</b>	<b>Time (mins)</b>
Plaice	190	5 - 6
Filletts	170	10 - 15
Goujons	190	3
Scampi	170	3 - 5
Fish cakes - small	170	3
Fish cakes - medium/large	170	4 - 5
Whitebait	190	2 - 3

### **Fish – fresh**

Fish has a high water content. Dry with paper towel, and coat before frying. Use whole, or cut into fillets, cutlets or goujons.

<b>Type</b>	<b>Temperature (°C)</b>	<b>Time (mins)</b>
Filletts, goujons, scampi, fish cakes	190	3 - 4
Whitebait	190	1 - 2

### **Meat**

Only deep fry fresh/thawed meat. Coat in egg and breadcrumbs or batter. For frozen meat products, follow directions on the package.

<b>Type</b>	<b>Temperature (°C)</b>	<b>Time (mins)</b>
Goujons	190	3
Chops/cutlets - small/large	170	10/15
Scotch eggs	170	10
Rissoles, meat balls	190	6
Weiner schnitzel (depending on thickness)	170	3-8

## Poultry

Only deep fry fresh or thawed poultry. Coat in egg and breadcrumbs or batter. Remove the skin for better results. Allow time for poultry to cook to the centre. A crisp golden exterior doesn't necessarily denote this, so test before serving. For frozen poultry product, follow directions on the package.

Type	Temperature (°C)	Time (mins)
Goujons	170	4
Drumsticks	170	14 - 15
Croquettes	190	2 - 3
Chicken in breadcrumbs - small	170	15 - 20
Chicken in breadcrumbs - large	170	20 - 30

## Bread, cakes, fritters

Type	Temperature (°C)	Time (mins)
Ring doughnuts	190	2
Pineapple, banana or apple fritters	190	2 - 3
Croutons (diced bread)	190	1

## Chocolate bars

1. Chill (don't freeze) a Mars® bar in the fridge for a couple of hours.
  2. Remove the wrapper and wipe off any condensation with paper towel.
  3. Coat the bar in beaten egg, then batter (basic, fritter, or depending on taste).
  4. Lower the battered bar gently into oil at 190°C and fry till light golden brown.
- Take care not to overcook.
  - This technique has also been applied successfully to the Milky Way® bar, the Snickers® bar, and the creme egg®.

---

## HINTS AND TIPS

- Adding food to the oil reduces the temperature of the oil.
- If you add a little food, the temperature will recover quickly, and the food will be cooked properly.
- When you put food into the appliance, you should see bubbles given off. This is steam, formed when the moisture inside the food heats up.
- The steam coming out of the food prevents oil from soaking into the food.
- The food cooks uniformly – firm and crisp.
- If you add too much food, the temperature will not recover, and your food will absorb oil.
- If the oil foams and threatens to overflow, there's too much food in the basket (take some out), the food is too moist (dry th food with paper towel and try again), or the oil is old or contaminated (replace it).
- Every time oil is heated, it deteriorates.
- Every time food is put into it, moisture, particles of food and fat, flour and spices from coatings, water from frozen foods, cause further deterioration.
- Particles blacken, burn, and stick to the next batch of food, altering its look and taste. Filtering the oil can alleviate this a little.



- Pre-cooked and oven chips have a coating of oil from the pre-cooking process. This will thicken and discolour the oil in your fryer.
- If you fry coated foods often, it's worth keeping two lots of oil, one for coated foods and one for "oil-friendly" foods. Keep them in separate, labelled containers.
- Even filtered oil will be past its best after 10 to 12 uses. It may look OK, but it'll already have affected the quality and taste of your food.
- As a rough guide, if you notice a marked improvement in flavour after changing the oil, you should have changed it earlier.
- Don't top up oil that's past its best. You're just wasting new oil.

---

## CARE AND MAINTENANCE

- Unplug the fryer and let it cool down fully before cleaning or moving it.
- Don't use harsh or abrasive cleaning agents or solvents.
- Don't put the control unit in water or any other liquid, and don't put it in the dishwasher.
- If you intend to move the fryer without emptying it, take great care, as it'll be heavy.

### Cleaning after every use

Wipe the outer surfaces with a clean damp cloth, dry thoroughly, and put the lid on top of the bowl to keep dust, etc. out of the oil.

### Full cleaning (after every few uses)

- Cover the work surface generously with paper towel (at least three layers thick).
  - You'll need a suitable container (5 litre) for the used cooking oil. If the container isn't wide necked, use a wide necked funnel.
  - If you want to filter the oil at the same time, support a fine sieve over a wide necked container, or fit the funnel with a filter paper.
1. Remove the lid.
  2. Grip the sides of the control unit and slide it straight up.
  3. The element is attached to the control unit – hold it over the bowl till most of the oil has drained back into the bowl.
  4. Set it down on the kitchen paper to drain further.
  5. If you're using a funnel, fit it to the oil container.
  6. Take care lifting the bowl – including the oil, it could weigh over 4 kilograms.
  7. Use the rim round the bowl to lift the bowl out of the base unit – take care not to spill.
  8. Pour the oil from one of the corners of the bowl into the container or funnel.
  9. If you're filtering at the same time, you'll need to pour the oil a little at a time, waiting till the last lot has filtered through before adding the next lot.
  10. Wash the body, lid, basket, and bowl in warm soapy water and dry thoroughly.
  11. Clean the control unit and element with a damp cloth.
  12. If a residue starts to build up on the element where it meets the surface of the oil, clean it off with a little detergent, and reduce the time between cleaning operations.
  13. Dry the element thoroughly and remove all trace of detergent before reassembling.

### Dishwasher

- You may wash the body, lid, basket, and bowl in a dishwasher.
- If you use a dishwasher, the harsh environment inside the dishwasher will affect the surface finishes. The damage should be cosmetic only, and should not affect the operation of the fryer.

### Discolouration

With use, the basket and element will discolour. This is inevitable, harmless, and won't affect the operation of the fryer.

## **Disposal of old oil**

- Never pour old oil down the sink or toilet. This can cause blockages.
- Don't put it in the wheelie bin.
- Your Local Authority will have a depot where old oil can be taken for recycling or environmentally friendly disposal.

---

## **THERMAL SAFETY CUT-OUT**

The cut-out operates to protect the element from overheating. If the fryer stops working:

1. Switch off, unplug, and let the fryer cool down.
2. Check the oil level.
3. If the oil level is below the MIN mark, reset the thermal safety cut-out.
4. If the oil level isn't too low, and the thermal safety cut-out has operated for some other reason, ring Customer Service Department.

### **To reset the thermal safety cut-out**

1. Find the reset button access hole. It's marked  on the rear of the power unit.
2. Inside the hole you'll see a round button.
3. Use the reset tool to press the button and reset the cut-out.
4. If you have lost the reset tool, you may purchase a replacement from Customer Service (see back page)
5. Top up the oil, plug the fryer in and switch on.
6. It should now work – if it doesn't, ring Customer Service.

---

## **STORING**

- If you're storing the fryer without removing the oil, then it's impractical to fold the handle into the basket.
- You may remove the handle altogether by pushing it forward, then squeezing the uprights till their ends come out of the clips.
- Fit the lid on top of the bowl to keep dust, etc. out of the oil.



---

## RECYCLING



To avoid environmental and health problems due to hazardous substances, appliances and rechargeable and non-rechargeable batteries marked with one of these symbols must not be disposed of with unsorted municipal waste. Always dispose of electrical and electronic products and, where applicable, rechargeable and non-rechargeable batteries, at an appropriate official recycling/collection point.

---

## SERVICE

If you ring Customer Service, please have the Model Number to hand, as we won't be able to help you without it. It's on the rating plate (usually underneath the product).

The product isn't user-serviceable. If it's not working, read the instructions, check the plug fuse and main fuse/circuit breaker. If it's still not working, consult your retailer.

If that doesn't solve the problem – ring Customer Service – they may be able to offer technical advice.

If they advise you to return the product to us, pack it carefully, include a note with your name, address, day phone number, and what's wrong. If under guarantee, say where and when purchased, and include proof of purchase (till receipt). Send it to:

Customer Service

Spectrum Brands (UK) Ltd

Fir Street, Failsworth, Manchester M35 0HS

email: [support@russellhobbs.com](mailto:support@russellhobbs.com)

telephone: 0345 658 9700 (local rate number)

Please note: If you have purchased the product within the last 6 months, please contact the retailer in the first instance to deal with any matters relating to warranty.

---

## GUARANTEE

Defects affecting product functionality appearing within the guarantee period will be corrected by replacement or repair at our option provided the product is used and maintained in accordance with the instructions. Your statutory rights are not affected.

Guarantee period = 2 years from first retail purchase.

To claim an extra 1 year guarantee, register your product online within 28 days of purchase.

Register at: [www.russellhobbs.co.uk/productregister/](http://www.russellhobbs.co.uk/productregister/)

Consumables are guaranteed only for their recommended lifecycle. Replacement/Spare parts\* are excluded and are only covered by a 1 year warranty.

\* Examples include filters, removable grill plates, drip trays/crumb trays etc.

---

## ONLINE

[www.russellhobbs.com](http://www.russellhobbs.com) for more products

---

## REGISTER ONLINE

Register online for an EXTRA year guarantee\*.

Visit [www.russellhobbs.co.uk/productregister/](http://www.russellhobbs.co.uk/productregister/)

\*You must register within 28 days of purchase.