



Russell Hobbs



24180

 www.russellhobbs.com

Register online for an EXTRA year guarantee

Visit www.russellhobbs.co.uk/productregister/ You must register within 28 days of purchase

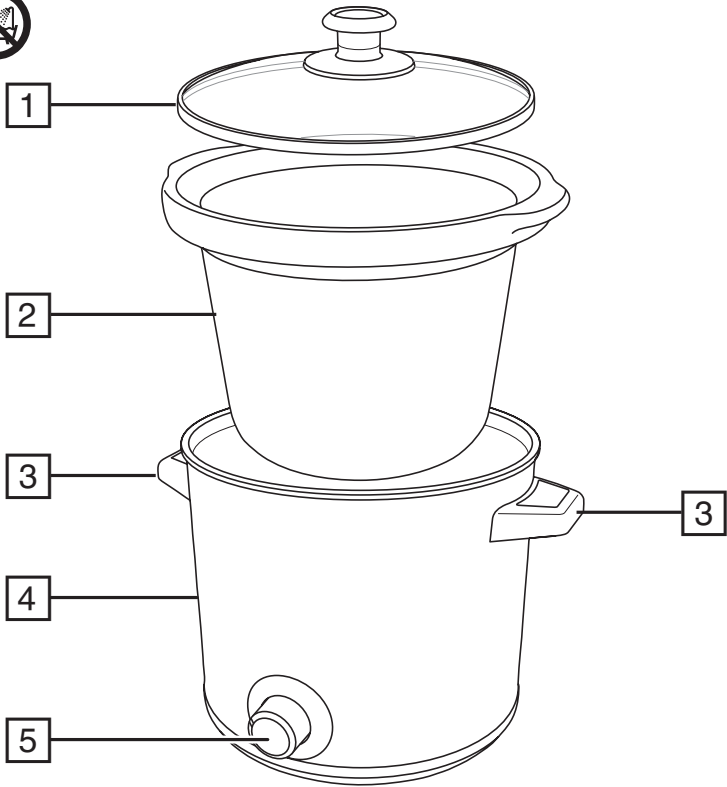

A

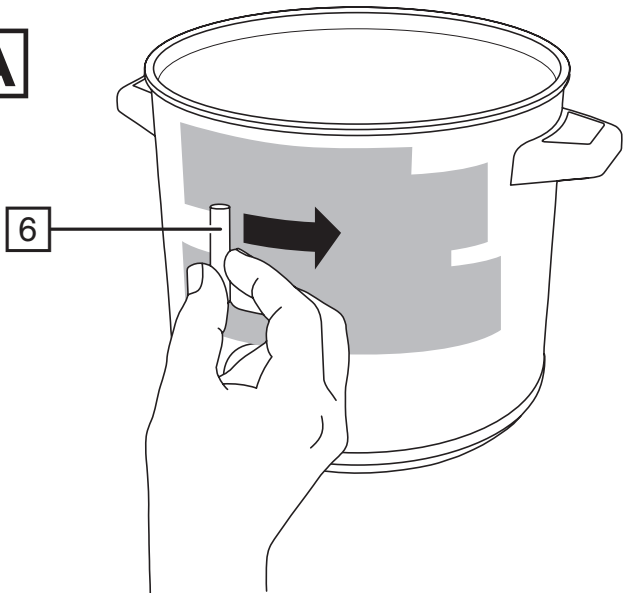



Read the instructions, keep them safe, pass them on if you pass the appliance on. Remove all packaging before use.

IMPORTANT SAFEGUARDS

Follow basic safety precautions, including:

This appliance can be used by children aged from 8 years and above and persons with reduced physical, sensory or mental capabilities or lack of experience and knowledge if they have been supervised/ instructed and understand the hazards involved. Children shall not play with the appliance. Cleaning and user maintenance shall not be done by children unless they are older than 8 and supervised. Keep the appliance and cable out of reach of children under 8 years. If the cable is damaged, it must be replaced by the manufacturer, its service agent, or someone similarly qualified, to avoid hazard.

 Do not use this appliance near bathtubs, showers, basins or other vessels containing water.

 The surfaces of the appliance will get hot.

- Leave a space of at least 50mm all round the appliance.
- Don't cover the appliance or put anything on top of it.
- Unplug the appliance when not in use, before moving and before cleaning.
- Don't use accessories or attachments other than those we supply.
- Don't use the appliance for any purpose other than those described in these instructions.
- Don't operate the appliance if it's damaged or malfunctions.

HOUSEHOLD USE ONLY

PARTS

- | | |
|----------------|----------------|
| 1. Lid | 4. Base unit |
| 2. Cooking pot | 5. Mode switch |
| 3. Handles | 6. Chalk |

BEFORE USING FOR THE FIRST TIME

Remove all packaging. Wash the cooking pot in warm soapy water. Rinse and dry. Wipe the inside and outside of the base unit with a damp cloth.

IMPORTANT: Before writing on your slow cooker with the supplied chalk you must prepare the surface. If you don't do this, the chalk may be difficult to erase afterwards. To condition the surface, rub the writing area of your slow cooker with the side of the chalk to give an even coating (Fig A). Wipe off the coating of chalk with a soft cloth and the surface is now conditioned and ready to use. The exterior of your slow cooker will become hot during use. Only write on your slow cooker before cooking or when it has cooled down.

THE BENEFITS OF SLOW COOKING

Health: The gentle cooking action reduces damage to vitamins and retains more of the nutrients and flavours.

Economy: Long, slow cooking can tenderise cheaper, tougher cuts of meat, and uses about a quarter of the power of other cooking methods.

Convenience: Prepare the ingredients the night before, put them in the slow cooker in the morning before you leave for work and have a delicious meal waiting for you when you get home.

COOKING MODES

- **LOW** for traditional slow cooking (typically 8-10 hours).
- **HIGH** for faster cooking (typically 4-5 hours).
- **WARM** for keeping food warm before serving (only after it has been fully cooked in the slow cooker).

CAUTION Never use the **LOW** or **WARM** settings to reheat food.

USING YOUR SLOW COOKER

1. Place your slow cooker on a stable, level, heat-resistant surface.
2. Put the prepared ingredients into the cooking pot.
3. Put the cooking pot into the slow cooker then fit the lid.
4. Plug the slow cooker into a wall socket.
5. Turn the mode switch to **LOW** or **HIGH** as required. Cooking will start.
6. When cooking is finished turn the mode switch to the **WARM** position. If you want to serve the food right away, turn the control to **OFF** and unplug your slow cooker. Don't use the **WARM** setting for longer than 4 hours.
7. Always use oven gloves when handling the lid or cooking pot.

CARE AND MAINTENANCE

Cleaning can be made much easier if you immediately remove all the cooked food from the cooking pot, then fill it with warm water. Otherwise residual heat may bake food debris on to the cooking pot, making its eventual removal more difficult.

1. Unplug your slow cooker and allow it to cool.
2. Wash the lid and cooking pot in hot soapy water, using a cloth or sponge, then rinse and dry thoroughly. Don't use scouring pads.
3. All other surfaces, internal and external, should be wiped with a damp cloth. You may use a little washing-up liquid, if necessary.
4. Dry all surfaces thoroughly before re-using the slow cooker or storing it away.
5. You may wash the cooking pot and lid in a dishwasher, but the harsh environment inside the dishwasher may affect the surface finishes. Any damage should be cosmetic, and should not affect the functionality of the cooker.

COOKING GUIDELINES

General

- When testing a dish to see if it's cooked, don't forget that root vegetables usually take longer to cook than the meat.
- Thaw frozen food completely before adding it to the cooking pot.
- Brown the meat and sauté the vegetables in a pan.
- Store ingredients prepared beforehand (e.g. the night before) in containers in the fridge. Don't put the slow cooker or the cooking pot into the fridge.
- When cooking with rice, use at least 150ml of cooking liquid for each 100g of rice. Easy-cook style rice gives the best results.
- If your recipe requires pasta, it should be stirred in 30-40 minutes before the end of the cooking time.
- Food can sometimes dry out on the **HIGH** setting. If it looks like drying out add a little hot water.

Vegetables

Slow cooking is ideal for vegetables because all the juices and flavours are retained. However, they will take longer to cook than the meat. Cut them into 5 - 6 mm slices, sticks or dice and make sure that they are immersed in the cooking liquid. Vegetables that cook quickly like frozen peas and sweetcorn must be thawed first then added half an hour before the end of cooking.

Pulses (Beans, Peas and Lentils)

WARNING boil dried beans (e.g. red kidney beans) for at least 10 minutes, drain, then add to the slow cooker. They're poisonous if eaten raw or under cooked.

Soak dried peas or beans overnight. Don't soak lentils. For canned beans or peas, simply drain and add them 30 minutes before the end of the cooking time.

Fish

Cooking fish in the slow cooker helps to develop the delicate flavours of fish and retain nutrients.

1. Grease the base of the cooking pot with butter or margarine.
2. Clean, trim and wash the fish (rolled fillets and steaks are most suitable). Dry and place in the cooking pot. Frozen fish should be completely thawed before slow cooking.
3. Season well, sprinkle with lemon juice, then add stock, water or wine
4. Dot some butter over the fish and cook on **LOW** for 2-3 hours.

Meat

Slow cooking tenderises cheaper cuts, reduces shrinkage and evaporation, and retains flavour and nutritive value. The size and shape of the joint, its quality, and the proportion of lean, fat and bone, all affect cooking times. Thaw frozen meat completely before cooking. Recipe times are given only as a guide. Where a different cut of meat is used cooking times may need to be adjusted. Avoid meat with a high proportion of fat, or trim the excess fat. Small joints (up to 800g) can be cooked, depending on shape and fit. The meat must not prevent the lid from closing.

1. Season the meat, then brown on all sides.
2. Transfer to the slow cooker and cook at **HIGH** for the time shown.
3. Pork joints with rind may be grilled for 10 minutes to crisp the rind.
4. If possible, turn joints once during cooking to ensure even tenderness.

Joint	Weight	Setting	Time
Beef, lamb, pork	500-800g	HIGH	5-7 hours

Poultry

Cook poultry up to 750g. The meat must not prevent the lid from closing. Thaw frozen poultry before cooking. Cook whole poultry unstuffed, on **HIGH**.

1. Wash and dry the poultry and season inside and out.
2. Brown the skin in its own fat or a little cooking oil, in a pan on a hob.
3. Transfer to the slow cooker and cook on **HIGH** for the time shown.

Poultry	Weight	Setting	Time
Chicken/poussin	750g	HIGH	3½-4 hours
Pheasant	small	HIGH	3-4 hours

Slow Cooker Cooking Times (approximate times)

Food	Size/Weight	Time on LOW (hours)	Time on HIGH (hours)
Fish	whole	1-2	-
Beef	500-800g	7-10	5-7
Lamb	500-800g	6-9	4-6
Poultry	500-800g	8-10	3½-4
Stew	500-800g	9-14	6-8

Food	Size/Weight	Time on LOW (hours)	Time on HIGH (hours)
Vegetable soup	800-1000ml	6-10	3-4
Beef soup	800-1000ml	10-14	7-9

Converting Recipes from a Traditional Oven (approximate times)

Oven cooking time	Time on LOW (hours)	Time on HIGH (hours)
15-30 minutes	4-6	1-2
30-60 minutes	6-8	2-4
1-3 hours	8-12	4-7

A FEW RECIPES TO START YOU OFF

- Cooking for more than an hour over the times in the recipes may affect the flavour. Nevertheless, if these times don't suit you, feel free to experiment. Slow cooking is very forgiving.
- Use metric or imperial measures, don't mix them, they're not exact equivalents.
- Be careful with quantities. After all the ingredients are put into the cooking pot, it shouldn't be more than about threequarters full, to allow for expansion. If you overfill, it may spit hot water, and it may overflow during use.
- Slow cooking can leave too much liquid. If you want to adjust this, remove the lid, stir in a teaspoon of flour, and cook at **HIGH**, stirring, till the sauce thickens/reduces.
- For recipes that don't need ingredients searing put the cooking pot in the slow cooker, fit the lid, then preheat on **HIGH** for 20 minutes before putting anything into the cooking pot.

Minestrone Soup

LOW = 7-10 hours; **HIGH** = 4-5 hours

- 25g butter
- ½ clove garlic, crushed
- 1 leek, sliced
- 1 small carrot, chopped small
- 1 medium potato, chopped
- 1 small onion, chopped
- ½ celery stick, thinly sliced
- 50g cabbage, finely shredded
- 200g canned tomatoes including juice
- 300ml chicken stock
- 1 bay leaf
- 1 bouquet garni
- 25g thin cut macaroni
- salt and pepper to taste

Heat the butter in a large pan. Add the garlic, leek, carrot, potato, onion and celery. Sauté till the butter is absorbed. Add the other ingredients, except the macaroni. Bring to the boil, transfer to the cookpot and cook for the time shown. 45 minutes before serving, remove the bay leaf and bouquet garni and add the macaroni. Adjust seasoning and serve with grated parmesan.

Old Fashioned Vegetable Soup

LOW = 8-10 hours; **HIGH** = 4-6 hours

- 225g mixed vegetables, chopped (potato, onion, carrot, celery etc.)
- 25g butter
- 2 tbsp flour
- 200ml stock
- ½ tsp mixed herbs
- salt and pepper to taste

Melt the butter in a pan and fry the vegetables gently for 2-3 minutes. Stir in the flour and add the stock. Bring to the boil, season to taste and add mixed herbs. Transfer to the slow cooker.

Ratatouille

LOW = 6-8 hours; **HIGH** = 4-5 hours

- 1 small aubergine, sliced
- 50g butter
- 1 green pepper, deseeded and diced
- 1 onion, chopped
- 1 red pepper, deseeded and diced
- 1 clove garlic, crushed
- 397g can chopped tomatoes
- 2 courgettes, sliced
- salt and pepper to taste

Slice the aubergine and sprinkle with salt. Leave for half an hour, rinse and pat dry. In a large pan melt the butter and fry the onion and garlic till transparent. Mix in the remaining ingredients, and cook for a further 2 minutes, stirring, then add to the cookpot. Cook for the time shown.

Stuffed Tomatoes

LOW = 3-4 hours; **HIGH** = 1-2 hours

- 4 large, firm tomatoes
- 50g fresh bread crumbs
- 50g boiled ham, finely chopped
- 50g cheese, grated
- 1 tsp chopped parsley
- salt and pepper to taste

Cut a lid off the top of each tomato and scoop out the pulp. Mix the ham, cheese, breadcrumbs, seasoning, parsley, and a little of the tomato pulp to bind the mixture. Spoon into the tomatoes. Stand the tomatoes in the cooking pot, add any extra filling and 1 tbsp water.

Vegetarian Curry

LOW = 6-10 hours; **HIGH** = 3-4 hours

- 1 tbsp cooking oil
- ½ onion, chopped
- ½ clove garlic, crushed
- ¼ tsp chilli
- ¼ tsp turmeric
- ¼ tsp coriander
- ¼ tsp cumin
- 50g lentils
- 300ml white stock
- ½ tsp lemon juice
- 1 small carrot, diced
- ½ apple, peeled, cored and chopped
- 15g sultanas
- salt and pepper to taste

Heat the oil in a pan. Lightly sauté the onion and garlic. Add the turmeric, chilli, coriander, cumin and lentils. Cook gently for a minute. Stir in the stock, lemon juice, salt and pepper. Bring to the boil and boil for 5 minutes. Transfer to the cookpot and stir in the carrots, apple and sultanas.

Poached Cutlets of Salmon

LOW = 2-3 hours

- 175g-225g salmon cutlet
- 100ml water
- 3 tbsp white wine
- ½ tsp salt
- 1 bay leaf
- 2 peppercorns
- 1 thin slice of onion
- 1 sprig parsley

Put the cutlet on a piece of baking parchment and put into the cooking pot. Put the other ingredients into a pan, bring to the boil, then pour over the salmon. Replace the lid and cook for the time shown. Lift from the cooking pot, then remove the parchment, bone and skin.

Serve hot with melted butter or hollandaise sauce. To serve cold, transfer the salmon to a dish and pour over the cooking liquid. When cold, drain and serve with salad or coat with aspic made from the liquid.

Stuffed Mackerel

LOW = 3-4 hours

- 1 tomato, skin, deseed and chop
- 2 mackerel fillets
- ½ cooking apple, peel, core and cho
- 2 tsp lemon juice
- ½ slice of bread, crumbled
- chopped parsley to taste

Lay the mackerel out, skin side down, season and sprinkle with lemon juice. Mix the other ingredients, and spread thickly over the mackerel. Roll up from head to tail, and secure with a cocktail stick or thread. Butter baking parchment and the bottom of the cooking pot, put the parchment in the cooking pot and the fish on the parchment. Cook for the time shown.

Portuguese Haddock

LOW = 2-3 hours

- 25g butter
- 1 small onion, very thinly sliced
- 2 haddock or cod steaks or fillets
- 1 bay leaf
- 298g can condensed cream of tomato soup
- salt and pepper to taste

Butter the bottom of the cooking pot. Lay the onion on the butter, then the fish and bay leaf. Season. Boil the tomato soup in a pan, stirring well, and pour over the fish. Cook for the time shown. Remove the bay leaf before serving.

Beef and Vegetable Casserole with Dumplings

LOW = 7-10 hours; **HIGH** = 4-6 hours

- 450g stewing beef (shin/shoulder/chuck)
- 275ml beef stock
- 2 tbsp flour
- 1 carrot, thinly sliced
- 1 tbsp cooking oil
- salt and pepper to taste
- 1 small onions, sliced

for the dumplings:

- 25g self-raising flour
- ¼ tsp salt
- 12g shredded suet
- 1 tbsp chopped parsley
- 5 tsp cold water

Cut the meat in cubes and toss in seasoned flour. Heat the oil in a pan and brown the meat. Transfer to the cookpot. Fry the onions lightly in the pan. Stir in the remaining flour, gradually add the stock and carrots. Bring to the boil, transfer to the cookpot, and cook.

Make the dumplings by mixing flour, salt, suet and parsley. Add water and mix to a soft dough. Shape into 4 balls. Add to the casserole and cook at **HIGH** for 45 minutes with the lid on.

Braised Liver and Onions

LOW = 5-7 hours; **HIGH** = 2-4 hours

- 225g lambs liver, thinly sliced
- 2 tbsp cooking oil
- 25g plain flour
- 1 large onion, thinly sliced
- 300ml beef stock

Heat the oil in a frying pan. Coat the liver in the flour and fry till sealed. Transfer to the slow cooker. Add the onions to the pan and fry till golden. Stir in the remaining flour and stock. Bring to the boil, stirring. Pour over the liver and cook for the time shown. Serve with grilled bacon.

Bolognese Sauce

LOW = 6-10 hours; **HIGH** = 3-4 hours

- 1 tbsp cooking oil
- 1 small onion, finely chopped
- 1 clove garlic, crushed
- 350g minced beef
- 200g tinned chopped tomatoes incl. juice
- 100g tomato purée
- 100ml - 200ml beef stock
- 60g button mushrooms, sliced
- 1 tsp dried basil
- 1 bay leaf
- 1 bouquet garni
- 1 tbsp dried mixed peppers

Heat the oil in a pan, and fry the onion and garlic lightly. Add the beef, and fry till brown. Stir in the other ingredients. Bring to the boil, transfer to the cookpot, and cook for the time shown. Remove the bay leaf and bouquet garni. Serve with spaghetti or noodles, and grated parmesan.

Boiled Bacon in Apple Juice

HIGH = 4-5 hours

- 500g collar of bacon
- 275ml apple juice
- 1 small onion, sliced
- 1 tbsp cornflour
- freshly ground black pepper to taste

Put the bacon in a large pan, cover with cold water, and bring to the boil. Put the bacon in the cookpot, and discard the water. Put the apple juice and onion in the pan, bring to the boil, and pour over the bacon. Add pepper. Cook for the time shown. Remove the bacon to a serving dish, and keep hot.

Put the cornflour in a small pan and blend with a little cold water. Gradually stir in the apple juice. Bring to the boil and simmer for 2 minutes. Serve with the bacon.

Braised Brisket of Beef

HIGH = 6-8 hours

- 750g brisket
- salt and pepper to taste
- 25g butter
- 1 onion, chopped
- 1 carrot, finely chopped
- 150ml beef stock
- 1 bay leaf
- flour or cornflour to thicken

Season the meat. Heat the butter in a pan and brown the meat. Transfer to the slow cooker. Fry the onion and carrot till the onion is transparent. Add stock and bay leaf and bring to the boil. Pour round the meat. Cook for the time shown. Remove the meat to a serving dish. Keep hot. Strain the stock. In a pan, blend a little flour with cold water to make a paste. Gradually add the stock. Bring to the boil, stirring. Adjust the seasoning. Serve the gravy with the meat.

Pork and Pineapple Curry

LOW = 6-8 hours; **HIGH** = 3-4 hours

- 500g lean pork (cut into cubes)
- 25g flour
- 1 tsp salt
- 2 tbsp cooking oil
- 1 large onion, chopped
- 1 tbsp curry powder
- 1 tbsp paprika pepper
- 300ml chicken stock
- 1 dried red chillies
- 1 tbsp mango chutney
- 1 tsp Worcestershire sauce
- 225g tinned pineapple cubes incl. juice
- 2 bay leaves

Toss the pork in the flour and salt. In a large pan heat the oil and brown the meat. Lift out on to a plate with a draining spoon. In the same pan, fry the onions till soft. Stir in the curry powder and paprika pepper. Fry for 2 minutes then return meat to the pan. Stir well and cook for a few minutes. Add remaining ingredients, bring to the boil and transfer to slow cooker. Cook for the recommended time. Remove bay leaves before serving.

Beef in Guinness

LOW = 6-8 hours

- 675g shin of beef
- 300ml Guinness
- 2 medium onions, sliced
- 1 tbsp oil
- 3 tbsp soy sauce
- 1 tbsp mushroom ketchup
- seasoned flour

Cut the beef into 4 pieces, and toss in the seasoned flour. Heat the oil in a pan, brown the beef all over, then transfer to the slow cooker. Add the Guinness, soy sauce, and mushroom ketchup to the pan, and bring to the boil. Pour over the meat, then cook on **LOW** for 6-8 hours.

Savoury Pork Casserole

LOW = 6-10 hours; **HIGH** = 3-4 hours

- 1 tbsp cooking oil
- 250g lean pork, cubed
- 1 small onion, sliced
- 1 tbsp flour
- 150ml white wine
- 90ml chicken stock
- 2 tbsp tomato purée
- ½ green pepper, deseed and chop
- 75g button mushrooms
- salt and pepper to taste
- ½ tsp dried sage
- 1 tomato, skin, deseed and slice

Heat the oil in a large pan and lightly brown the pork. Add the onions. Stir in the flour and add the wine, stock and tomato purée. Add the green peppers and mushrooms. Bring to the boil, season and add sage and tomatoes. Transfer to the cookpot and cook for the time shown.

Boeuf Bourguignonne

LOW = 7-10 hours; **HIGH** = 4-6 hours

- 1 tbsp cooking oil
- 500g stewing steak, cubed
- 50g streaky bacon, chopped
- 1 tbsp flour
- 150ml red wine
- 1 tbsp brandy
- 150ml stock
- good pinch thyme
- 1 bay leaf
- 1 clove garlic, crushed
- 6-8 shallots or tiny onions, whole
- salt and pepper to taste

Heat the oil in a pan, lightly brown the beef and bacon, add the flour, stir in the wine and brandy. Add the other ingredients and season. Bring to the boil, transfer to the cookpot, and cook for the time shown. Remove the bay leaf before serving.

Coq Au Vin

LOW = 8-10 hours; **HIGH** = 3½-5 hours

- 2 chicken joints, skinned
- 1 tbsp cooking oil
- 100g streaky bacon, chopped
- 40g flour
- 1 onion, chopped
- 200ml chicken stock
- 200ml red wine
- 100g button mushrooms, sliced
- 1 bay leaf
- 1 clove
- 1 bouquet garni
- salt and pepper to taste

Heat the oil in a pan. Coat the chicken in seasoned flour and brown all over. Transfer to the cookpot. Put the bacon and onion in the pan and soften but don't brown. Stir in the remaining flour and add the other ingredients. Bring to the boil, stirring, and pour over the chicken. Cook for the time shown. Remove the bay leaf, clove and bouquet garni before serving.

Country Chicken Casserole

LOW = 8-10 hours; **HIGH** = 5-7 hours

- 200g tinned tomatoes, in. juice
- 2 chicken joints, skinned
- 100g tinned sweet corn, drained
- 1 stick celery, finely chopped
- 1 small onion, finely chopped
- 25g white cabbage, finely shredded
- 1 bay leaf
- ½ tsp mixed herbs
- 160ml chicken stock, boiling
- salt and freshly ground black pepper to taste

Put all the ingredients into the cooking pot making sure that the fresh vegetables are covered by the boiling hot stock. Cook for the time shown.

Chinese Chicken and Mushroom

LOW = 8-10 hours; **HIGH** = 3½-5 hours

- 1 tbsp cooking oil
- 2 chicken joints
- 1 onion, roughly chopped
- 2 tbsp cornflour
- 150ml chicken stock
- 225g button mushrooms, halved
- 2 tbsp soy sauce
- juice of 1 lemon
- 1 tsp sugar
- salt and pepper to taste

Heat the oil in a large pan and fry the chicken till golden brown. Transfer to the cookpot. In the remaining oil, fry the onions till transparent, stir in the cornflour, then gradually stir in the stock. Add the other ingredients, bring to the boil, pour over the chicken, and cook for the time shown.

Chicken with Barbecue Sauce

HIGH = 4½-5 hours

- 750g chicken breast or thigh meat
- 30g butter
- 1 small onion, finely chopped
- 2 tbsp tomato ketchup
- 1 tbsp vinegar
- 3 tbsp mango chutney, chopped
- ¼ tsp French mustard
- ½ tsp caster sugar
- 1½ tsp Worcestershire sauce
- salt and pepper to taste

Rub inside the cookpot with a little of the butter. Season the chicken. Heat the remaining butter in a large pan and brown the chicken pieces all over. Transfer to the cookpot. Put the onion in the pan and fry for 2-3 minutes, without colouring. Add the other ingredients and bring to the boil. Pour over the chicken and cook for the time shown.

Pears in Red Wine

LOW = 6-8 hours; **HIGH** = 3-5 hours

- 75g sugar
- 400ml red wine
- Rind and juice of 2 lemons
- 2 cloves
- 2 medium or 1 large ripe pear(s)

Put the sugar, wine, lemon rind, juice and cloves in a pan. Heat gently, stir till the sugar dissolves, then take off the heat. Peel the pears, leaving them whole, complete with stalks. Stand them in the cookpot, stalks upwards, and pour over the syrup. Cook for the time shown, turning the pears occasionally, so they're evenly coated with the syrup and colour evenly. Remove the cloves, and serve hot or chilled with cream.

Rhubarb and Orange

LOW = 3-4 hours; **HIGH** = 2-2½ hours

- 500g rhubarb
- 75g sugar
- grated rind and juice of 1 medium orange
- 300ml water

Wash the rhubarb and cut into 2.5cm (1") pieces. Put the ingredients into the cookpot and cook for the time shown.

Baked Stuffed Apple

LOW = 4-6 hours; **HIGH** = 2-3 hours

- 1 knob butter
- 50g soft brown sugar
- 25g sultanas
- 1 large cooking apple, cored
- 150ml boiling water

Grease the cookpot with the butter. Core the apple. Use a sharp knife to score the skin round the equator on the apple. Mix the sugar and sultanas and pack tightly inside the apple. Fold a square of foil to form a saucer. Put the foil in the cookpot, sit the apple on the foil, and pour the boiling water round it. Cook for the time shown. The cooking time for this recipe may vary with different types of apples.

Creamy Rice Pudding

LOW = 5-7 hours; **HIGH** = 4-4½ hours

- 15g butter
- 400ml milk
- 150ml evaporated milk
- 50g pudding Rice
- 25g sugar

Butter the inside of the cookpot. Add all the ingredients and stir. Cook for the time shown.

Brandy and Orange Punch

LOW = 3-5 hours; **HIGH** = 1-2 hours

- 150g sugar
- 300ml boiling water
- 6 cloves
- 1 tsp cinnamon
- zest and juice of 1 lemon
- juice of 1 orange
- 1 orange, sliced
- 2 tbsp orange squash
- ¼ bottle white wine
- 150ml brandy

Put the sugar and boiling water into the cookpot. Stir in the other ingredients except the brandy. Heat for the time shown. Stir in the brandy just before serving.

Apple Chutney

LOW = 8-9 hours; **HIGH** = 3-5 hours

- 750g apples, peeled and finely chopped
- 225g onions, finely chopped
- 350g light brown sugar
- 100g sultanas
- 150ml white wine vinegar
- 2 tbsp cornflour
- 2 tsp salt
- 1 clove garlic, crushed
- pinch cayenne pepper
- ½ tsp ground cinnamon
- ½ tsp ground ginger

Put the apples, onions, brown sugar and sultanas into the slow cooker. Mix the cornflour and vinegar together in a small bowl till completely smooth. Add the cornflour/vinegar mix to the slow cooker with the salt, garlic, cayenne pepper, cinnamon and ginger. Stir well. Cook for the time shown. Pour into heated jars and cover in the usual way. Alternatively, store in a container in the refrigerator for up to 2 weeks.

RECYCLING



To avoid environmental and health problems due to hazardous substances, appliances and rechargeable and non-rechargeable batteries marked with one of these symbols must not be disposed of with unsorted municipal waste. Always dispose of electrical and electronic products and, where applicable, rechargeable and non-rechargeable batteries, at an appropriate official recycling/collection point.

SERVICE

If you ring Customer Service, please have the Model Number to hand, as we won't be able to help you without it. It's on the rating plate (usually underneath the product).

The product isn't user-serviceable. If it's not working, read the instructions, check the plug fuse and main fuse/circuit breaker. If it's still not working, consult your retailer.

If that doesn't solve the problem – ring Customer Service – they may be able to offer technical advice.

If they advise you to return the product to us, pack it carefully, include a note with your name, address, day phone number, and what's wrong. If under guarantee, say where and when purchased, and include proof of purchase (till receipt). Send it to:

Customer Service

Spectrum Brands (UK) Ltd

Fir Street, Failsworth, Manchester M35 0HS

email: support@russellhobbs.com

telephone: 0345 658 9700 (local rate number)

Please note: If you have purchased the product within the last 6 months, please contact the retailer in the first instance to deal with any matters relating to warranty.

GUARANTEE

Defects affecting product functionality appearing within the guarantee period will be corrected by replacement or repair at our option provided the product is used and maintained in accordance with the instructions. Your statutory rights are not affected.

Guarantee period = 2 years from first retail purchase.

To claim an extra 1 year guarantee, register your product online within 28 days of purchase.

Register at: www.russellhobbs.co.uk/productregister/

Consumables are guaranteed only for their recommended lifecycle. Replacement/Spare parts* are excluded and are only covered by a 1 year warranty.

* Examples include filters, removable grill plates, drip trays/crumb trays etc.

ONLINE

www.russellhobbs.com for more products

REGISTER ONLINE

Register online for an EXTRA year guarantee*.

Visit www.russellhobbs.co.uk/productregister/

*You must register within 28 days of purchase.