



HEATED FOOT WARMER



Russell Hobbs

A BRITISH ICON SINCE 1952

RHSL1001-AU

Operating Manual

russellhobbs.com.au

russellhobbs.co.nz

CONTENTS

	Page(s)
Safety Instructions and Electrical Safety	3-6
Heated Foot Warmer Feature Diagram	7
Control Feature Diagram	8
Using your Heated Foot Warmer	9-10
Cleaning and Care	11-14
Problem Solving and Recycling	15
Customer Service & Warranty	16-17
Notes	18-19
Specifications	20



Read this guide carefully before installing or operating your new appliance and keep it somewhere safe for future reference.

SAFETY INSTRUCTIONS

When using an electrical appliance, basic safety precautions should always be followed to reduce the risk of fire, electric shock, and/or injury, including the following:

- Read all instructions.
- Check that your mains voltage corresponds with the rating on the appliance.
- To protect against electrical shock do not immerse cord, plug, or appliance in water or other liquid. Do not operate with wet hands.
- Do not operate any appliance with a damaged cord or plug, or after the appliance malfunctions or is dropped or damaged in any manner.
- The use of accessory attachments is not recommended by the appliance manufacturer and may cause fire, electric shock or injury.
- This appliance must not be immersed when in use or plugged in
- To disconnect remove the plug from the mains outlet. Do not pull the plug out by the cord.
- The appliance must not be used over or under a waterbed.
- Never use the appliance near a bath, shower or a swimming pool.
- Never place flammable objects or clothing on top of the appliance.
- Never use the appliance in a room with explosive gas such as petrol, or while using any kinds of flammable glues, sprays or solvents.
- This appliance is not intended for commercial use
- **This product is intended for household use only.** It is not intended for use in hospitals.
- Do not use outdoors.

SAFETY INSTRUCTIONS

- If the supply cord is damaged, it must be replaced by the manufacturer, its service agent or similarly qualified persons in order to avoid a hazard.
- Never leave an appliance unattended while in use.
- Do not walk around with the foot warmer on.
- This product is only intended for heating.
- If overheating should occur, the built-in overheating safety device will shut the appliance off.
- When in use, ensure that the appliance and power cord can not become caught or rucked.
- Do not use this appliance for infants, persons with no/limited mobility or heat sensitivity conditions.
- Do not use with wired area tucked in.
- Do not tuck in anywhere.
- Do not use pins, needles, safety pins or other sharp items on your heated foot warmer.
- Use only for human use, not for pets
- Keep the control unit away from open windows.
- **WARNING:** It is hazardous for anyone other than a competent person to carry out any service or repair operation which involves the removal of a cover which gives protection against exposure to electrical parts.
- **WARNING :** This appliance is not intended for use by persons (including children) with reduced physical, sensory or mental capabilities, or lack of experience and knowledge, unless they have been given supervision or instruction concerning use of the appliance by a person responsible for their safety. Children should be supervised to make sure that they do not play with the appliance.

SAFETY INSTRUCTIONS

- If any abnormality or defect in operation of this appliance is observed, discontinue its use immediately and consult the manufacturer or a licensed electrician.
- Regularly inspect the supply cord, plug, controller and appliance for any damage. If found damaged in any way, immediately cease use of the appliance and return to store or authorised service agent for inspection.
- Avoid pressing creases into the appliance.
- Clean this appliance only as per the cleaning instructions supplied.
- The appliance is only to be used with the type of control unit marked on the appliance.
- Avoid creasing the appliance by placing items on top of it during storage.
- When storing the appliance allow it to cool down before packing away.
- When storing, place neatly but not tightly in the original packaging without sharp bends in the heating element and store where no other objects will be placed upon it.
- There are no customer serviceable parts inside; Have the foot warmer serviced by a qualified service agent should the unit require access to internal components.
- The appliance is not to be used for warming animals.
- Outdoor shoes must be removed before use.
- This appliance must not be used by persons insensitive to heat and other vulnerable persons who are unable to react to overheating.
- Children under the age of three are not to use this appliance due to their inability to react to overheating.

ELECTRICAL SAFETY

- Before switching on, make sure that the voltage of your electricity supply is the same as that indicated on the rating plate. This product is designed to operate on 220 – 240V AC; 50Hz. Connection to any other power source may damage the unit.
- The installation of a residual current device (safety switch) is recommended to provide additional safety protection when using electrical appliances. It is advisable that a safety switch with a rated residual operating current not exceeding 30mA be installed in the electrical circuit. See your electrician for professional advice.



Do not dry clean



Not to be used by children under 3 years old



Do not use pins in the heated foot warmer



Do not iron



Machine wash at maximum 40°C



Do not tumble dry



Do not bleach

HEATED FOOT WARMER FEATURE DIAGRAM

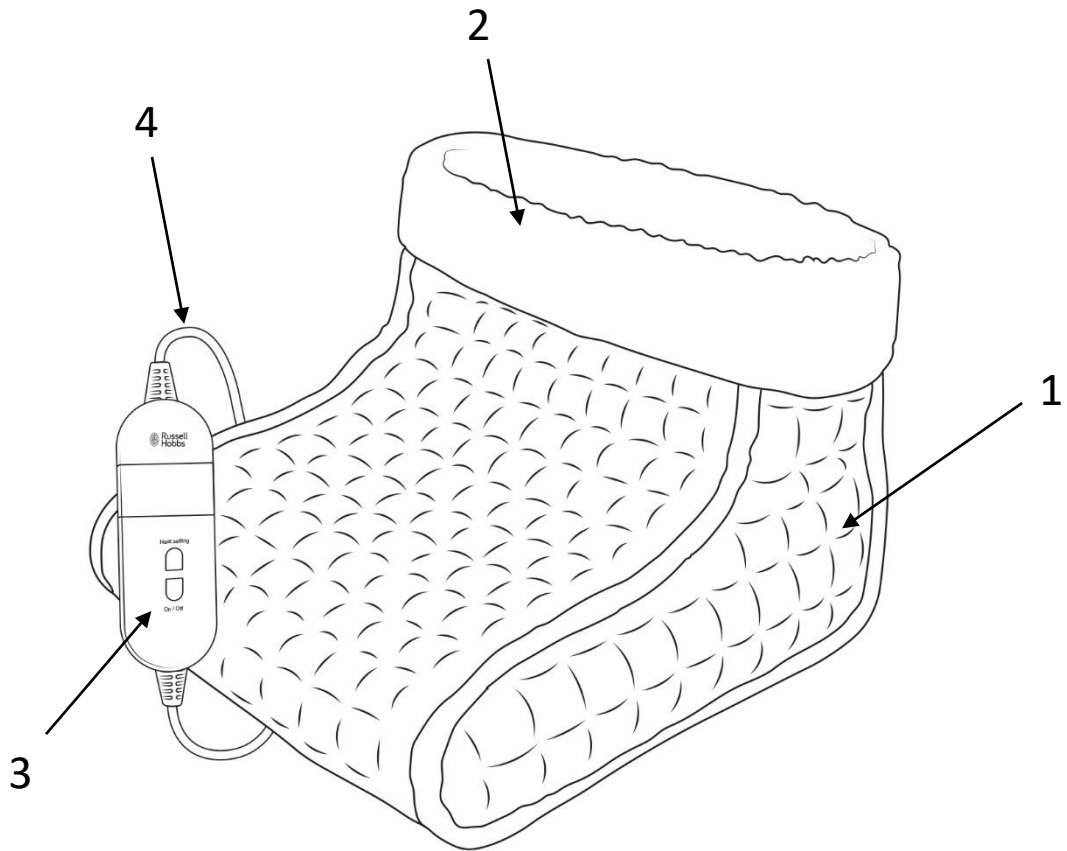

1. Heated Foot Warmer
2. Removable fleece lining
3. Controller
4. Detachable power cord

CONTROL FEATURE DIAGRAM

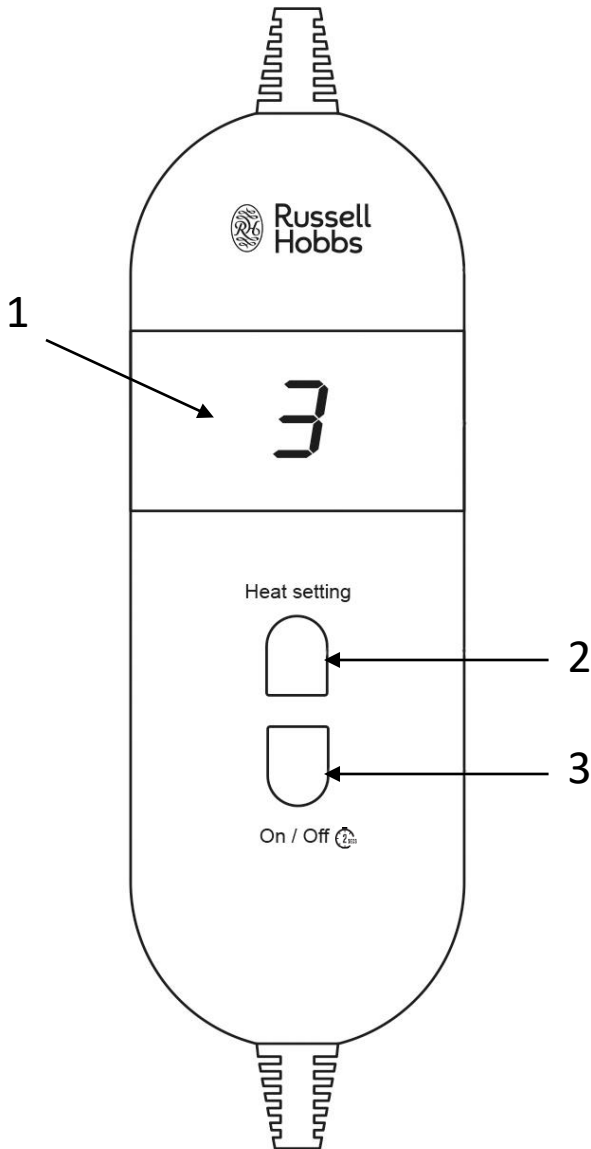

1. Heat setting display
2. Heat setting adjustment button
3. Power button

USING YOUR HEATED FOOT WARMER

Ensure you remove all packaging and inspect for damage prior to use. If damage is found do not use the appliance.

1. Place the foot warmer next to a chair on a level, dry, and heat-resistant surface.
2. Ensure the removable fleece lining is placed into the foot warmer.
3. Secure the detachable power cord to the foot warmer if not already attached.
4. If required, use an extension lead so the mains cable is not stretched.
5. Push the “**On/Off**” button to turn on the appliance. The default setting will display; this is heat setting “**0**”.
6. Adjust the temperature by pressing the “**Heat Setting**” button; this will enable you to select a heat setting from 1-3. For reference: 3 = high heat, 2 = medium heat, and 1 = low heat.
7. Press and hold the “**On/Off**” button for at least 2 seconds to turn off the appliance.

Note: It is recommended to preheat the foot warmer for 10 - 15 minutes.

Note: The lead between the controller and foot warmer may get warm during use. This is normal and safe.

Note: The appliance will automatically turn itself off after 2 hours of continuous operation.

Note: You may notice an odour when using the foot warmer for the first time, due to the insulation material. This is harmless and will subside quickly.

USING YOUR HEATED FOOT WARMER

Note: If you use this appliance for an extended period of time, the low setting (1) should be used in order to avoid conditions such as skin burns and/or heat stroke.

Note: Ensure all cords are arranged in such a way that they are safe and cannot cause a risk of entanglement, strangulation, tripping or treading.

Safety Protective Devices

Overheat Protection System - The system will remain dormant indefinitely as long as the foot warmer is operating in the normal temperature range. If, for any reason, the foot warmer is operated in an abnormal situation or condition which would otherwise have induced a rapid temperature rise high enough to constitute a hazard, the overheat protection should intervene by cutting off the supply current before the temperature reaches the point at which damage may occur. In the event of the overheat protection operating, the foot warmer will cease to function.

Auto-Off Feature - This appliance has an Auto-Off feature. The foot warmer will turn off after 2 hours of continuous use.

Note: No attempt should be made to repair the foot warmer or have it repaired locally. The switch supplied must never be replaced since the specialised components are not generally available.

Note: The controller **MUST** remain uncovered during use.

CLEANING AND CARE

WARNING: Electrical Shock Hazard.

Note: Before any cleaning, ensure the appliance is turned off and remove the plug from the wall socket.

Note: Do not allow the controller to come in contact with any wet solution.

Before you clean the appliance, disconnect the mains plug from the wall socket.

Detach the control

- Lift the tab on the controller attached to the plastic connector on the appliance; carefully pull the plug connector away from the appliance. The controller must NEVER be immersed in water.

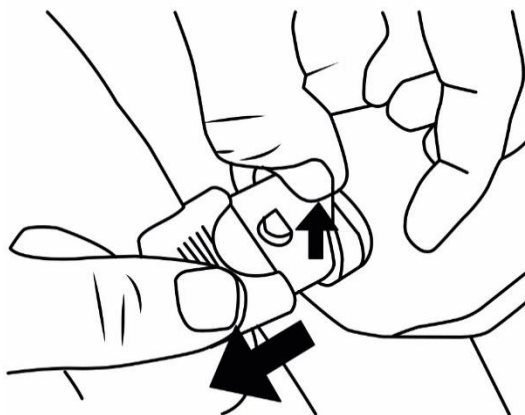

**DISCONNECT
BEFORE
CLEANING**

- The heating wires within the foot warmer are fully water-proof.

CLEANING AND CARE

Washing instructions

Only use the below instructions:

- Detach the controller
- Do not machine wash **above** 40°C
- Do not tumble dry
- Do not wring
- Do not bleach
- Do not dry clean
- Do not iron
- Do not immerse the controller, supply cord or plug in any liquid.

Spot Cleaning the Heated Foot Warmer

Detach the controller and sponge the affected area using a lukewarm neutral detergent or mild soapy solution. Ensure that no water gets into the connection socket at the back of the foot warmer. Follow this with a sponging using a clean water solution. Remove any excess water by compressing the wet area between absorbent towels. Let the heated foot warmer dry completely before using it again.

Hand Washing the Heated Foot Warmer & Fleece Lining

- If spot cleaning is not possible, the heated foot warmer may be hand washed.
- Detach the controller and separate the foot warmer from the fleece lining and wash separately.

CLEANING AND CARE



- Except for the connection socket on the back of the foot warmer, carefully immerse it (**Do not allow the controller to come in contact with any wet solution**), in a lukewarm neutral detergent or mild soapy solution.
- Soak for five minutes, remove from the solution, and gently squeeze the solution through the heated foot warmer.
- Rinse the heated foot warmer and fleece thoroughly (**Do not allow the controller to come in contact with any wet solution**), in clean lukewarm water; gently squeeze and drain the excess water.
- **Do not wring the appliance as this may damage the heating wires inside.**
- Drape the heated foot warmer across clothes lines and allow to drip dry completely before use.

Machine Washing the Heated Foot Warmer & Fleece Lining

- Detach the controller and separate the foot warmer from the fleece lining and wash separately.
- Do not let the controller come into contact with water.
- Wash in the washing machine on the shortest cycle at low temperature (maximum of 40°C) on a low spin washing and drying cycle.
- Rinse the heated foot warmer and fleece lining thoroughly in clean fresh water.
- Unfold the heated foot warmer and fleece lining and allow to dry naturally.

CLEANING AND CARE

Drying

- **Do not** tumble dry 
- **Do not** iron 
- **Do not** use pegs to secure the foot warmer in position.
- **Do not** dry with a hair dryer or heater.
- Drape the foot warmer across a clothes line and drip dry.

Cleaning the Plastic Parts

- Use a slightly damp cloth to wipe down the plastic parts of the appliance such as the control and the power cord.
- Let all parts completely dry before using the appliance again.

Note: Ensure the controls are in a position that will not allow dripping water to fall onto any part of the controller.

Storage

- When not in use, pack the foot warmer in its original packaging for best protection and store in a cool, clean and dry location. Avoid pressing sharp creases into the foot warmer.

PROBLEM SOLVING

My appliance does not work when I turn it on:

1. Check that your appliance is plugged in and the power is turned on at the mains socket.
2. Try another mains socket.
3. Check that the control has been set to the correct setting and is not in the off position
4. If the appliance still doesn't work, do not try to repair it yourself.

If your appliance power is automatically cut off, follow the step below:

1. Unplug your appliance from the mains socket and allow it to completely cool down.
2. Inspect your appliance. If there are any signs of physical damage (e.g. melting, or burning of the case), do not attempt to use the appliance. Please leave all maintenance work to qualified personnel.
3. Plug in the appliance and switch it on again. If it cuts off again, move the appliance to a better ventilated location.

RECYCLING

Legislation in some localities mandates that e-waste (anything with a plug, battery or cord) is disposed of through controlled recycling facilities and must not be disposed of in general household waste. For more information about recycling of electrical and battery operated appliances, please contact your local council or your local household waste disposal service.

CUSTOMER SERVICE & WARRANTY

Spectrum Brands Australia Pty Ltd
Locked Bag 3004 Braeside
Victoria 3195 Australia

Customer Service in Australia

Toll Free: 1800 623 118
Email: consumer.enquiry@russellhobbs.com.au
Website: www.spectrumbrands.com.au

Spectrum Brands New Zealand Ltd
PO Box 9817 Newmarket
Auckland 1149 New Zealand

Customer Service in New Zealand

Toll Free: 0800 736 776
Email: info@russellhobbs.co.nz
Website: www.spectrumbrands.co.nz

Spectrum Brands Australia Pty Ltd and Spectrum Brands New Zealand Ltd Warranty Against Defects

In this warranty:

Australian Consumer Law means the Australian consumer law set out in Schedule 2 to the Competition and Consumer Act 2010;

CGA means the New Zealand Consumer Guarantees Act 1993;

Goods means the product or equipment which was accompanied by this warranty and purchased in Australia or New Zealand, as the case may be;

Manufacturer, We or us means:

- for Goods purchased in Australia, Spectrum Brands Australia Pty Ltd ABN, 78 007 070 573; or
- for Goods purchased in New Zealand, Spectrum Brands New Zealand Ltd, as the case may be, contact details as set out at the end of this warranty;

Supplier means the authorized distributor or retailer of the Goods that sold you the Goods in Australia or in New Zealand; and

You means you, the original end-user purchaser of the Goods.

- Our goods come with guarantees that cannot be excluded under the Australian Consumer Law, or the CGA. You are entitled to a replacement or refund for a major failure and compensation for any other reasonably foreseeable loss or damage. You are also entitled to have the goods repaired or replaced if the goods fail to be of acceptable quality and the failure does not amount to a major failure.
- The benefits provided by this Warranty are in addition to all other rights and remedies in respect of the Goods which the consumer has under either the Australian Consumer Law or the CGA. The original purchaser of the Goods is provided with the following Warranty subject to the Warranty Conditions:
- We warrant the Goods for all parts defective in workmanship or materials for a period of 2 years from the date of purchase (Warranty Period).

If the Goods prove defective within the Warranty Period by reason of improper workmanship or material, we may, at our own discretion, repair or replace the Goods without charge.

WARRANTY CONDITIONS

1. The Goods must be used in accordance with the manufacturer's instructions. This Warranty does not apply should the defect in or failure of the Goods be attributable to misuse, abuse, accident or non-observance of manufacturer's instructions on the part of the user. As far as the law permits, the manufacturer does not accept liability for any direct or consequential loss, damage or other expense caused by or arising out of any failure to use the Goods in accordance with the manufacturer's instructions.
2. Exhaustible components (such as batteries, filters and brushes) of the Goods are included under this Warranty only where there is a defect in workmanship or materials used.
3. The warranty granted under clause 3 is limited to repair or replacement only.
4. Any parts of the Goods replaced during repairs or any product replaced remain the property of the manufacturer. In the event of the Goods being replaced during the Warranty Period, the warranty on the replacement Goods will expire on the same date as for the Warranty Period on the original Goods which are replaced.
5. In order to claim under the warranty granted under clause 3 you must:
 - a) Retain this warranty with your receipt/proof of purchase; and
 - b) Return the Goods to us at the relevant address or to the Supplier by prepaid freight within the Warranty Period accompanied with (i) the legible and unmodified original proof of purchase, which clearly indicates the name and address of the Supplier, the date and place of purchase, the product name or other product serial number and (ii) this warranty.
6. This warranty is immediately void if:
 - a) Any serial number or appliance plate is removed or defaced;
 - b) The Goods have been serviced or otherwise repaired by a person not authorised to do so by us or where non approved replaced parts are used.
7. The Goods are designed for domestic use only. The Goods must be connected to the electrical voltage requirements as specified in the ratings label located on the Goods.
8. This warranty does not cover the cost of claiming under the warranty or transport of the Goods to and from the Supplier or us.
9. This warranty is only valid and enforceable in Australia against Spectrum Brands Australia Pty Ltd and in New Zealand against Spectrum Brands New Zealand Ltd.

Contact us or the Supplier for further details.

REGISTER YOUR PRODUCT ONLINE

Registration of your product is for marketing purposes only, not warranty registration.

If you live in Australia, please visit: <https://au.russellhobbs.com/product-registration>

If you live in New Zealand, please visit: <https://www.russellhobbs.co.nz/product-registration>

Registration entitles you to receive these benefits: Product information; Hints and tips; Recipes and news; Information on special price offers and promotions.

Please retain your receipt as proof of purchase for any warranty claims.

Any questions? Please contact Customer Service for advice.

NOTES

NOTES

SPECIFICATIONS

Model number

RHSL1001-AU

Rated voltage

220V - 240V ~ 50Hz

Power consumption

28W (Max 60W)

