



Russell Hobbs



CLASSIC CHOPPER

2 YEAR WARRANTY

RHMFP2

RHMFP2_IB&RB_FA_021115

Part No. T22-5002772

INSTRUCTIONS & WARRANTY

Spectrum Brands Australia Pty Ltd

Locked Bag 3004 Braeside
Victoria 3195 Australia

Customer Service in Australia

TollFree: 1800 623 118
Email: info@spectrumbrands.com.au
Website: www.spectrumbrands.com.au

Spectrum Brands New Zealand Ltd

PO Box 9817 Newmarket
Auckland 1149 New Zealand

Customer Service in New Zealand

TollFree: 0800 736 776
Email: service@spectrumbrands.co.nz
Website: www.spectrumbrands.co.nz

Spectrum Brands Australia Pty Ltd and Spectrum Brands New Zealand Ltd Warranty Against Defects

In this warranty:

Australian Consumer Law means the Australian consumer law set out in Schedule 2 to the Competition and Consumer Act 2010;

CGA means the New Zealand Consumer Guarantees Act 1993;

Goods means the product or equipment which was accompanied by this warranty and purchased in Australia or New Zealand, as the case may be;

Manufacturer, We or **us** means:

1. for Goods purchased in Australia, Spectrum Brands Australia Pty Ltd ABN, 78 007 070 573;
or
2. for Goods purchased in New Zealand, Spectrum Brands New Zealand Ltd, as the case may be, contact details as set out at the end of this warranty;

Supplier means the authorised distributor or retailer of the Goods that sold you the Goods in Australia or in New Zealand; and

You means you, the original end-user purchaser of the Goods.

1. Our goods come with guarantees that cannot be excluded under the Australian Consumer Law, or the CGA. You are entitled to a replacement or refund for a major failure and compensation for any other reasonably foreseeable loss or damage. You are also entitled to have the goods repaired or replaced if the goods fail to be of acceptable quality and the failure does not amount to a major failure.
2. The benefits provided by this Warranty are in addition to all other rights and remedies in respect of the Goods which the consumer has under either the Australian Consumer Law or the CGA. The original purchaser of the Goods is provided with the following Warranty subject to the Warranty Conditions:
3. We warrant the Goods for all parts defective in workmanship or materials from the date of purchase (**Warranty Period**), for the period of 2 years from the date of purchase (**Warranty Period**).

If the Goods prove defective within the Warranty Period by reason of improper workmanship or material, we may, at our own discretion, repair or replace the Goods without charge.

Warranty Conditions

4. The Goods must be used in accordance with the manufacturer's instructions. This Warranty does not apply should the defect in or failure of the Goods be attributable to misuse, abuse, accident or non-observance of manufacturer's instructions on the part of the user. As far as the law permits, the manufacturer does not accept liability for any direct or consequential loss, damage or other expense caused by or arising out of any failure to use the Goods in accordance with the manufacturer's instructions.
 5. Exhaustible components (such as batteries, filters and brushes) of the Goods are included under this Warranty only where there is a defect in workmanship or materials used.
 6. The warranty granted under clause 3 is limited to repair or replacement only.
 7. Any parts of the Goods replaced during repairs or any product replaced remain the property of the manufacturer. In the event of the Goods being replaced during the Warranty Period, the warranty on the replacement Goods will expire on the same date as for the Warranty Period on the original Goods which are replaced.
 8. In order to claim under the warranty granted under clause 3 you must:
 - (a) Retain this warranty with your receipt/proof of purchase; and
 - (b) Return the Goods to us at the relevant address or to the Supplier by prepaid freight within the Warranty Period accompanied with (i) the legible and unmodified original proof of purchase, which clearly indicates the name and address of the Supplier, the date and place of purchase, the product name or other product serial number and (ii) this warranty.
 9. This warranty is immediately void if:
 - (a) Any serial number or appliance plate is removed or defaced;
 - (b) The Goods have been serviced or otherwise repaired by a person not authorised to do so by us or where non approved replaced parts are used.
 10. The Goods are designed for domestic use only. The Goods must be connected to the electrical voltage requirements as specified in the ratings label located on the Goods.
 11. This warranty does not cover the cost of claiming under the warranty or transport of the Goods to and from the Supplier or us.
 12. This warranty is only valid and enforceable in Australia against Spectrum Brands Australia Pty Ltd and in New Zealand against Spectrum Brands New Zealand Ltd.
- Contact us or the Supplier for further details.

Register your product online

If you live in Australia please visit: www.spectrumbrands.com.au/warranty

If you live in New Zealand Please visit: www.spectrumbrands.co.nz/warranty

Registration of your warranty is not compulsory, it gives us a record of your purchase AND entitles you to receive these benefits: Product information; Hints and tips; Recipes and news; Information on special price offers and promotions.

Any questions? Please contact Customer Service for advice.

Congratulations on the purchase of your new Russell Hobbs Classic Chopper. Each unit is manufactured to ensure safety and reliability. **Before using the Classic Chopper for the first time, please read this instruction booklet carefully and keep it for future reference.** Pass it on if you pass on the appliance.

When using this appliance, basic safety precautions should always be followed.

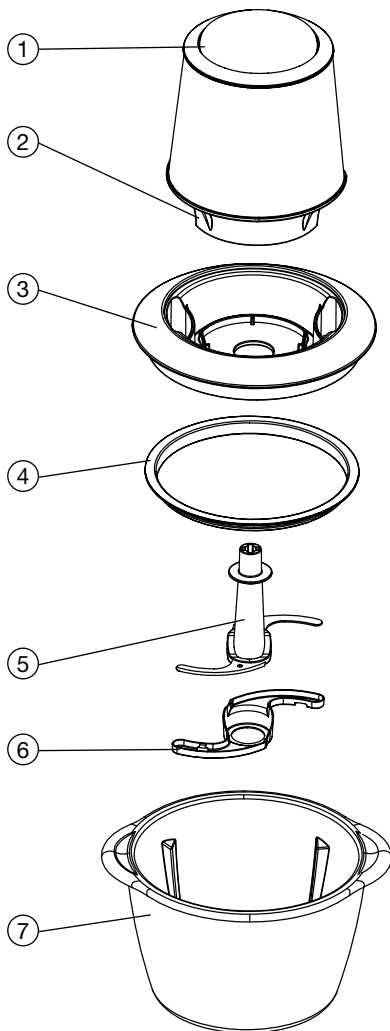

1. Pulse button
2. Motor Unit
3. Chopping Lid
4. Sealing ring
5. Blade unit
6. Blade protective cover
7. Chopper bowl

BEFORE FIRST USE

- Carefully remove all contents from the box.
- Take extreme care when unpacking and handling the sharp blades.
- As some parts may be packed separately, check to ensure all items have been unpacked before disposing of the packaging.
- All parts of the Classic Chopper need to be thoroughly cleaned before being used for the first time. (see 'CLEANING' section below)

USING THE CLASSIC CHOPPER

The Classic Chopper is ideal for chopping parsley, onions, hazelnuts, bread crumbs, biscuits, baby food, etc.

- Remove the protective cover from the chopper blade. Simply sit the blade on the central axis of the chopper bowl.
- Place the food into the bowl.
- Fit the lid onto the chopper bowl.
- Press the lid down lightly to activate the seal.
- Fit the motor unit onto the lid. Align by matching the notches on the lid with the indents on the underside of the motor unit.
- The motor unit will fit firmly into the notches on the lid.
- Place your hand around the motor unit to hold the chopper steady.
- Insert the plug into a wall power outlet and switch the outlet on.
- Press and hold the pulse button to start the motor.
- Release the pulse button to stop the motor.
- To disengage the motor unit from the chopper lid, lift the motor unit up.

CAUTION: Be sure the chopping blades have completely stopped spinning before removing the motor unit.

- To remove the lid from the chopper bowl, gently lift using the lid notches.
- After use, switch off the wall power outlet and remove the plug.

PRACTICAL HINTS

- The preparation must cover the chopping blade for the mix to be successful.
- Leave cooked foods to cool for a while before processing.
- Watch carefully to avoid over-processed foods.
- Do not overload the bowl. The processor will not work efficiently if more than 2/3 full.
- Always insert the chopping blades first before filling with food.
- Do not chop food or liquids that are at a temperature of 40°C or higher.
- For fibrous foods (leeks, celery, asparagus, etc) clean the centre shaft of the blade unit regularly during use.
- Follow the safety instructions for disassembly and cleaning.
- For fruit-based preparations, first cut up the fruit into manageable sized pieces and remove pips and stones.
- Use short bursts only when processing hard foods like coffee beans, ice cubes, sugar, cereals and chocolate.

CLEANING

CAUTION: Always unplug from the wall power outlet before cleaning.

- Clean the chopping blade immediately after each use. If the plastic parts become discoloured by food like carrots, rub them with a cloth soaked in cooking oil and then clean as usual.
- Once the blades are dry re-attach the protective cover to the blade.
- Do not immerse the motor unit in water or place in a dishwasher. Clean with a damp cloth and warm soapy water.
- Wash the blades, blade cover and storage lid in warm water and with a little washing liquid.
- Dry thoroughly before storing.

SAFEGUARDS

When using this appliance, basic safety precautions should always be followed, including the following:

Read all instructions before, and follow whilst using this appliance.

1. To protect against electrical hazards, do not immerse the power cord, plug or motor unit in water or any other liquid.
2. Do not use outdoors or in damp or moist areas.
3. Always use the appliance handles when handling.
4. This appliance is not intended for use by persons (including children) with reduced physical, sensory or mental capabilities, or lack of experience and knowledge, unless they have been given supervision or instruction concerning use of the appliance by a person responsible for their safety.
5. Cleaning or user maintenance shall not be carried out by children without the supervision of a person responsible for their safety.
6. Care should be taken to avoid personal injury when handling the sharp cutting blades, emptying the bowl and during cleaning. Use a glove or a towel for safety.
7. Always switch off and disconnect the appliance from the wall power outlet before assembling, disassembling, cleaning or if the appliance is left unattended.
8. Always switch off and disconnect the appliance from the wall power outlet when not in use.
9. To disconnect, switch off the wall power outlet, then grasp and pull the plug from wall outlet. Never pull by the cord.
10. Do not operate this appliance with a damaged cord/plug or after the appliance has malfunctioned, been dropped or damaged in any manner. Contact Customer Service for examination, adjustment, repair or replacement.
11. There are no user serviceable parts. If the power cord is damaged, it must be replaced by the manufacturer or similarly qualified person in order to avoid a hazard.
12. Do not use on an inclined plane or unstable surface.
13. Keep the appliance and power cord away from the edges of benches and countertops.
14. Keep hands and utensils away from moving blades when in use to prevent the possibility of severe personal injury and damage to the appliance. A plastic/silicone scraper may be used, but only when the appliance is not running.
15. Be certain the chopper lid is securely fitted and all fittings such as blades are secure before using.
16. Do not operate the motor unit without the attachments fitted.
17. Always cut food items into manageable pieces before processing.
18. When mixing heavy loads, the appliance should not be operated for longer than 10 seconds.
19. Ensure the motor unit is switched off and the blades have come to a complete stop before removing processed contents.
20. For your safety, do not mix liquids/foods that are hotter than 40°C.
21. Do not overfill the mixing/processing containers.
22. Do not place on or near any heat sources.
23. CAUTION: The blades are extremely sharp. Handle with care.
24. Store the blades in a safe location out of reach of children or persons with disabilities.
25. Follow the instructions when cleaning this appliance.
26. Do not use alkaline cleaning agents or harsh abrasives when cleaning this appliance.
27. Always thoroughly clean the appliance after each use.
28. Do not use the appliance for other than its intended purpose.
29. Misuse of the appliance may cause injury.
30. This appliance is not a toy. Children shall be supervised to ensure they do not play with this appliance.
31. This appliance is not intended to be operated by means of an external timer or separate remote control system.
32. For added safety, electrical appliances should be connected to a power outlet that is protected by a residual current device (RCD), also often referred to as a 'Safety Switch'. Your switchboard may already incorporate an RCD. If unsure, call an electrician for verification and fitting if necessary.
33. This appliance is intended to be used in household and similar applications such as:
 - Staff kitchen areas in shops, offices and other working environments;
 - Farm houses;
 - By clients in hotels, motels, and other residential type environments;
 - Bed & breakfast type environments

SAVE THESE INSTRUCTIONS

BREAKFAST SMOOTHIE

Ingredients:

2 tbsp natural yogurt

100ml milk

1 tbsp oatmeal or

porridge oats

1 large banana,
roughly chopped

1 tsp honey

apple, cored and
roughly chopped

Method:

1. Put everything into the bowl.
2. Process for 15-20 seconds if you like a rough texture,
30-40 seconds if you prefer it smooth.

CORIANDER PESTO

(dip, topping or sauce)

Ingredients:

2 handfuls fresh leaf coriander
3 cloves fresh garlic
60g pine nuts
125ml olive oil
60g freshly grated Parmesan
Salt and freshly ground black pepper to taste

Method:

1. Put the coriander, garlic, pine nuts, and a bit more than half the oil into the bowl, and process till the mixture looks smooth.
2. To adjust the thickness, add a little oil and give it a short burst of speed.
3. Repeat till the consistency looks right, then taste it, and adjust the seasoning.
4. Serve as a dip, as a topping for soup, or tossed through warm pasta.

BLACK OLIVE AND ANCHOVY TAPENADE/SAUCE

Ingredients:

250g pitted black olives
60g anchovy fillets, drained
3 tbsp capers, drained
150ml olive oil
2 tbsp brandy (optional)
Fresh ground black pepper

Method:

1. Pour half the oil, and put everything else into the bowl.
2. Process for a couple of seconds, then check the mixture.
3. Pour the remainder of the oil and process, till you achieve the consistency you need.

Tip: For a tapenade, to spread on toast, you need a paste.

For a sauce, to toss through warm pasta, it should be fairly runny.

LEEK & POTATO SOUP

Ingredients:

75g leeks, trimmed
75g potatoes, peeled
1 vegetable or chicken
stock cube
400ml water
Salt and pepper to taste

Method:

1. Put the leeks and potatoes into the bowl, and process for a couple of seconds (you want them lumpy, not mushy).
2. Transfer to a pan, and add the water and stock cube.
3. Bring to the boil, stirring, then reduce the heat, cover the pan, and simmer for 20 minutes.
4. Let the mixture cool for about 30 minutes, then process till the mixture is silky smooth.
5. Return the mixture to the pan, and heat to serving temperature (don't let it boil, or it may separate).
6. Taste, adjust the seasoning, and serve with crusty bread.

Serves 2

www.russellhobbs.com.au

www.russellhobbs.co.nz

RUSSELL HOBBS® and logo are Trade Marks of Spectrum Brands, Inc., or one of its subsidiaries.
©2015 Spectrum Brands, Inc.

Recipes are to be used in conjunction with the RHMFP2 Classic Chopper by Russell Hobbs. All rights reserved. No part of this publication may be reproduced, stored in a retrieval system or transmitted in any form or by any means, electronic, mechanical, photocopying, recording or otherwise, without prior permission of the copyright owner.



Russell Hobbs



RECIPE BOOK

CLASSIC CHOPPER

RHMFP2

INSTRUCTIONS & WARRANTY